

**LAYOUT**

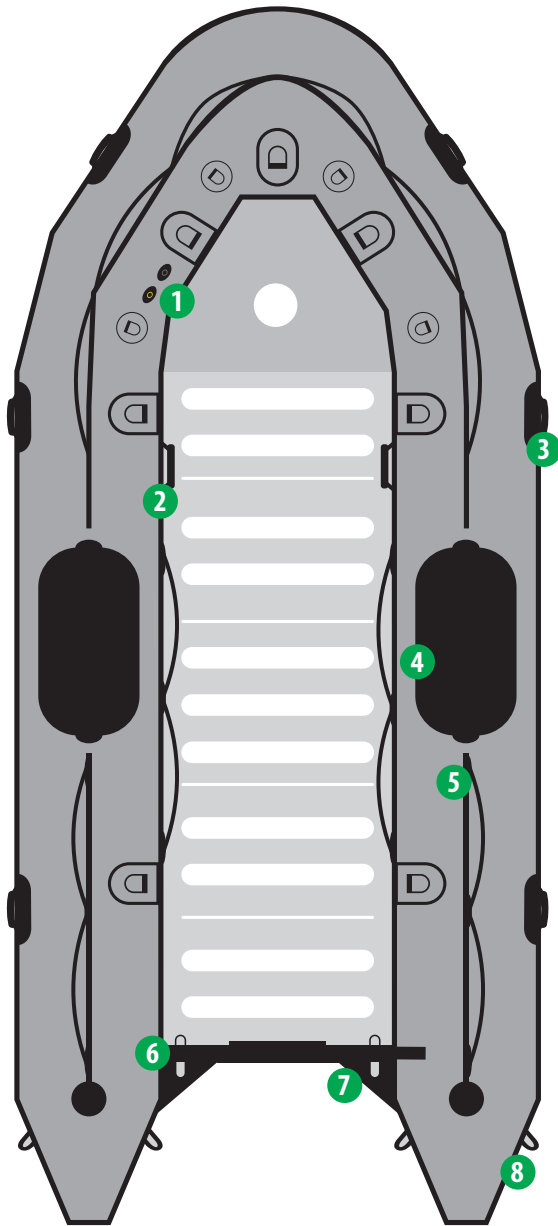

**MODEL COLORS**

**MEHLER**  
WELDED SEAMS



**FEATURES**

- 1.- Inflation and over inflation valves (One for each air chamber)
- 2.- Interior grab handles
- 3.- Exterior carry handles, non-slip design
- 4.- Dive patch
- 5.- Lifelines (Peripheral)
- 6.- Transom lifting rings (Stainless steel)
- 7.- Splash guard
- 8.- Two large D-rings on rear tubes (Stainless steel)
- 9.- Epoxy coated plywood transom
- 10.- Standard self bailer with plug (Pop-up design)
- 11.- Performance tubes (Optional)
- 12.- Bow handle (Stainless)
- 13.- Two large tow rings on bow (Stainless steel)
- 14.- Keel rub strake
- 15.- All around rub strake, flat profile, black

**REAR**

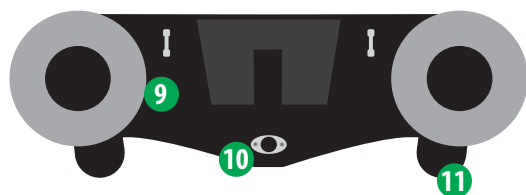

**SIDE**



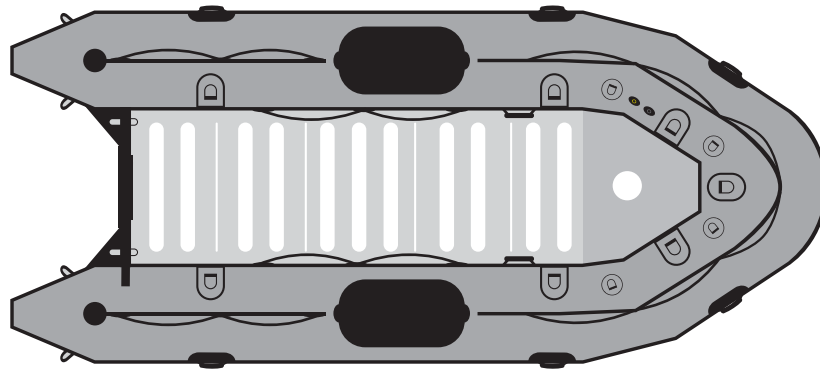

### CAPACITY

Passenger capacity:	6
Max payload:	1,750 lbs
Floorboard usable area:	22,2 ft <sup>2</sup>
Buoyancy tube volume:	36,4 ft <sup>3</sup>

### FABRIC / SEAM CONSTRUCTIONS

Mehler 1.2mm (1450 dtx)  
RF welded / temperature resistance -30 °C / +70 °C

### VALVES

Inflation valves on main tube:	4
Keel inflation valve:	1
Overinflation valves:	4

### REINFORCEMENTS

All around rub strake, flat profile, black:	1
Flat rub strake underneath keel, black:	1
Splash guard:	2

### HANDLING

Lateral carrying handles:	6
Exterior lifeline (peripheral):	3
Interior lifelines:	2
Interior large tie down D-Ring:	7
Bow bag D-Ring:	4

### FACTORY WARRANTY

3 years recreational / 1 year commercial

### TRANSOM

Self-bailers	1
Aluminum engine mounting plate:	1
Transom sacrificial plate (marine plywood)	1

### ENGINE (aluminum floor)

Recommended power (aluminum floor)	20 HP
Max power (aluminum floor):	30 HP
Shaft length:	20" long shaft
Max engine weight:	175 lb

### DIMENSIONS

Overall length:	12' 5"
Inner length:	8' 7"
Overall width:	6' 5"
Inner width:	3' 0"
Tube diameter:	20"
Boat weight with floor:	220 lbs

### INFLATION

Air chambers on main tube:	4
Inflatable keel:	1

### TOWING AND LIFTING

D-Rings:	Stainless steel
Bow carrying handle:	1
Rear large towing D-Ring:	2
Rear lifting points in transome:	2

### SHIPPING INFORMATION



#### BOAT

- Package dimensions: 52x34x20
- Package weight: 193 lbs.



#### FLOOR

- Floor dimensions: 45x40x7
- Floor package weight: 109 lbs.

**FLOOR OPTIONS**

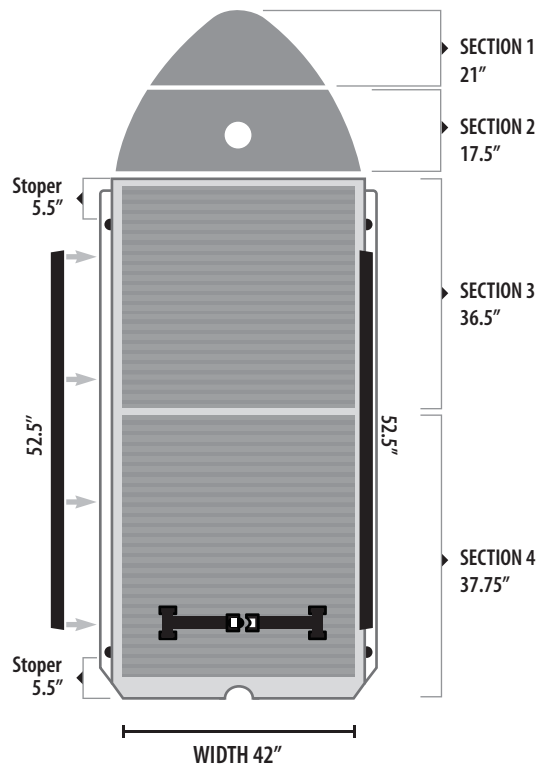

**ALUMINUM FLOOR**

24 mm profile gauge  
5086 marine grade-treated  
Non skid EVA traction pads

- Front floor boards (marine plywood) \_\_\_\_\_ 2
- Aluminum sectional flooring \_\_\_\_\_ 2
- Side locking rails \_\_\_\_\_ 2

*\*Floor must be removed prior to roll-up storage*

**OPTIONAL EQUIPMENT**



Quick inflation system



SCBA Adaptor



High flow scuppers



Bow bag



6 gl fuel bladder



Performance tubes

1



*\*Optional reflective panel*

2



3



*\*Aluminum floor shown*

4



5



6



7



*\*Optional performance tubes*

8

